

## **USER MANUAL**

GEWA Digital Piano **DP 340 G**



Bedienungsanleitung | User manual | Mode d'emploi | Manual de instrucciones  
[www.gewakeys.com](http://www.gewakeys.com)



**Read these operating instructions before use and observe the safety information!**  
**Keep the instruction manual for future reference.**

Manufacturer:  
GEWA music GmbH  
Werkstraße 1  
08626 Adorf  
GERMANY

[www.gewamusic.com](http://www.gewamusic.com)

Version 1.0

Last update: 10.04.2019

---

<b>1</b>	<b>SAFETY INFORMATION .....</b>	<b>5</b>
1.1	Key .....	5
1.2	Intended use .....	6
1.3	Improper use .....	6
1.4	Precautions .....	7
1.5	CE mark .....	8
1.6	Disposal .....	8
<b>2</b>	<b>DELIVERY.....</b>	<b>9</b>
<b>3</b>	<b>ASSEMBLY INSTRUCTIONS .....</b>	<b>10</b>
<b>4</b>	<b>FIRST STEPS .....</b>	<b>12</b>
4.1	Control elements of your digital piano .....	12
4.2	Control buttons and pedals .....	13
4.3	Keyboard / Connections panel / Back.....	15
<b>5</b>	<b>OPERATING USE .....</b>	<b>17</b>
5.1	Switching on .....	17
5.2	DEMO function .....	17
5.3	Choice of sounds .....	17
5.3.1	Dual Mode .....	18
5.4	Reverb and Chorus .....	18
5.4.1	Reverb .....	18
5.4.2	Chorus and other effects .....	19
5.5	Metronome .....	19
5.5.1	Metronome - switching on/off .....	19
5.5.2	Metronome - changing speed .....	20
5.5.3	Changing time signature .....	20
5.5.4	Metronome - volume adjustment .....	20
<b>6</b>	<b>FUNCTIONS MENU .....</b>	<b>20</b>
6.1	Settings .....	21
6.2	Transposition .....	21
6.3	Fine-tuning the sounds .....	22
6.4	Touch function / touch sensitivity .....	22
6.5	Balance settings .....	22
6.6	Brilliance settings .....	23
6.7	MIDI transmission channel .....	23
6.8	Local Control .....	23
6.9	Program Change function .....	24
6.10	Piano mode .....	24
6.11	Changing the tuning .....	25
6.11.1	Changing the root note .....	25
6.12	Adjusting string resonance .....	25
6.13	Adjusting damper resonance .....	26
6.14	Adjusting LINE IN input volume .....	26
6.15	Auto Power Off .....	26
6.16	Layer Pedal .....	26
<b>7</b>	<b>RECORDING AND PLAYBACK FUNCTIONS .....</b>	<b>27</b>
7.1	Recording music .....	27
7.2	Playback of recordings .....	27
7.3	Deleting recordings .....	27

---

<b>8</b>	<b>USER CALIBRATION OF THE KEYBOARD</b> .....	<b>28</b>
8.1	Selecting the calibration mode .....	28
8.2	Creating a user calibration .....	28
8.3	Comparing factory and user calibration .....	29
8.4	Exit calibration mode .....	29
<b>9</b>	<b>CONNECTING EXTERNAL DEVICES (ACCESSORIES)</b> .....	<b>30</b>
9.1	Connecting headphones .....	30
9.2	Connecting a playback device .....	30
9.3	Connecting an amplifier .....	30
9.4	Connecting to PC .....	30
<b>10</b>	<b>USEFUL INFORMATION</b> .....	<b>31</b>
10.1	INDEX .....	31
10.2	Warranty .....	32
<b>11</b>	<b>TROUBLESHOOTING</b> .....	<b>33</b>
<b>12</b>	<b>TECHNICAL SPECIFICATIONS</b> .....	<b>34</b>

Dear Customer,

Thank you for choosing a digital piano from GEWA music!

You have chosen a high-quality digital piano that will give you an impressive sound experience and lots of fun.

Additional functions extend the capabilities of your digital piano far beyond piano playing.

Your safety is very important to us!

Please read the safety information carefully and pay close attention to it. Retain this manual and hand it over to the respective user.

# 1

## SAFETY INFORMATION



NOTE





The manufacturer is not liable for personal injury or property damage resulting from improper use of the device!

Only use your digital piano as directed!

### 1.1

#### KEY

The following symbols are used in this operating manual to identify hazards and notes.

Level of danger	Symbol	Importance	Definition
Severe injury		<b>WARNING</b>	Severe to fatal injuries if disregarded
Severe injury through electric shock		<b>WARNING</b>	Additional symbol for danger of electric shock
Slight injury and property damage		<b>CAUTION</b>	Slight injury and / or property damage can occur if the safety instructions are disregarded.
Note		<b>NOTE</b>	Crucial information concerning the handling of the device
Tip		<b>TIP</b>	Application tips

## 1.2

### INTENDED USE

The digital piano is intended for use in dry rooms.

- Devices for audio playback (as input or output) or for data communication can be connected. However, the respective technical specifications must be complied with (see the section "Technical data").
- The electrical connection may only be made to correctly installed power supplies, fulfilling the respective regulations. The mains voltage on the identification plate must correspond to the mains voltage of the country of use.
- The digital piano is only to be used in the original delivery condition described below. Conversions of any kind are not permitted and cause the immediate loss of the warranty claim.
- The digital piano must be placed on securely fastened and weight-suitable, stable and level floors or platforms.

## 1.3

### IMPROPER USE – EXAMPLES:

- Use outdoors or in rain
- Use in damp rooms
- Connection to incorrect supply voltage or improperly installed electrical power supplies.
- Use in close proximity to electrical or electronic equipment such as stereos, televisions, radios or mobile phones.
- These devices may cause interference and affect the sound quality.
- Electrical leads that are too long can also affect sound quality.
- Transport and installation in places or vehicles with strong vibration, dust and strong heat e.g. direct sunlight.

The manufacturer accepts no liability for damage for the following reasons:

- Disregard of the safety instructions
- Improper handling
- Use with devices that are not compatible with the technical data listed below



NOTE

## 1.4

### PRECAUTIONS

Please follow the the precautions listed here. Disregard of precautionary measures can have serious consequences:

- Severe injury or even fatal accidents
- Electric shock
- Short circuit
- Damage
- Fire

Other threats are conceivable; this is not an exhaustive list.



**WARNING**



#### **Fatal electric shocks**

- Even low electrical currents can lead to serious injuries and death.
- Never open the digital piano's casing.
- Never use damaged power cables.
- Lay the power cable in such a way that it can not be damaged.
- Never place containers (vases, glasses etc) filled with water or fluids on the piano.
- Never pour water or liquids on to the digital piano or keyboard.
- Never clean the digital piano with a wet cloth.
- Never plug in or pull out the mains plug with wet hands. Never pull on the cable; it can cause damage.
- If liquid accidentally gets into the digital piano, immediately unplug the power. Then have your digital piano checked by your GEWA service representative.



**WARNING**

#### **Unusual circumstances**

- Turn off the digital piano or unplug the power cable if:
  - There is a sudden loss of sound while using the digital piano
  - The digital piano generates an unusual smell or smoke
- Be sure to have the digital piano checked by your GEWA service representative



**WARNING**

#### **Protection against fire**

- Open flames such as candles or tealights can tip over and cause a fire
- Never place objects with open flames on the digital piano!



**CAUTION**

**Damage to the digital piano**

- Inappropriate electrical voltages can damage the digital piano.
- Only operate the digital piano in the permissible voltage range (as indicated on the respective identification plate).
- Only use the supplied power cable.
- Never place the power cable near to sources of heat, such as radiators or freestanding heaters.
- Do not bend or kink the power cable, or damage it in any other way.
- Lay the power cable so that nobody can step on it, trip on it or roll over it.
- Do not place objects on the power cable.
- Regularly check the power cable and remove any dust or dirt that may be present.



**CAUTION**



**Damage to the digital piano through thunderstorms**

- Thunderstorms can generate electrical surges that can damage electrical equipment.
- In the event of a thunderstorm or long periods of non-use (such as travel), unplug the appliance from the mains.

1.5



CE MARK

CE MARK

This device complies with EU directive requirements: **Directive 2014/53/EU**

**EN55020**:2007+A11:2011

**EN55024**:2010

**EN55032**:2012

**EN61000-3-2**:2014

**EN61000-3-3**:2013

**EN301489-17**:V2.2.1

**EN301489-17**:V3.2.0

**EN62479**:2010

**EN300328**:V2.1.1

The conformity with the regulations listed above is confirmed by the CE sign on the device. The declaration of conformity can be viewed at the following address:

GEWA music GmbH, Werkstraße 1, 08626 Adorf, GERMANY

1.6



DISPOSAL

To dispose of the old device, please take it to your local waste management authority (e.g. disposal company or recycling centre).

The adjacent symbol indicates that the device must be disposed of separately from household waste. In accordance with the Electrical and Electronic Equipment Act, owners of old appliances are legally required to dispose of old electrical and electronic appliances at a separate and designated waste disposal point.

Please help in contributing to protect the environment by not disposing of the old device in household waste.



# 2

## DELIVERY

Check that the contents of the package is complete before commencing with assembly.

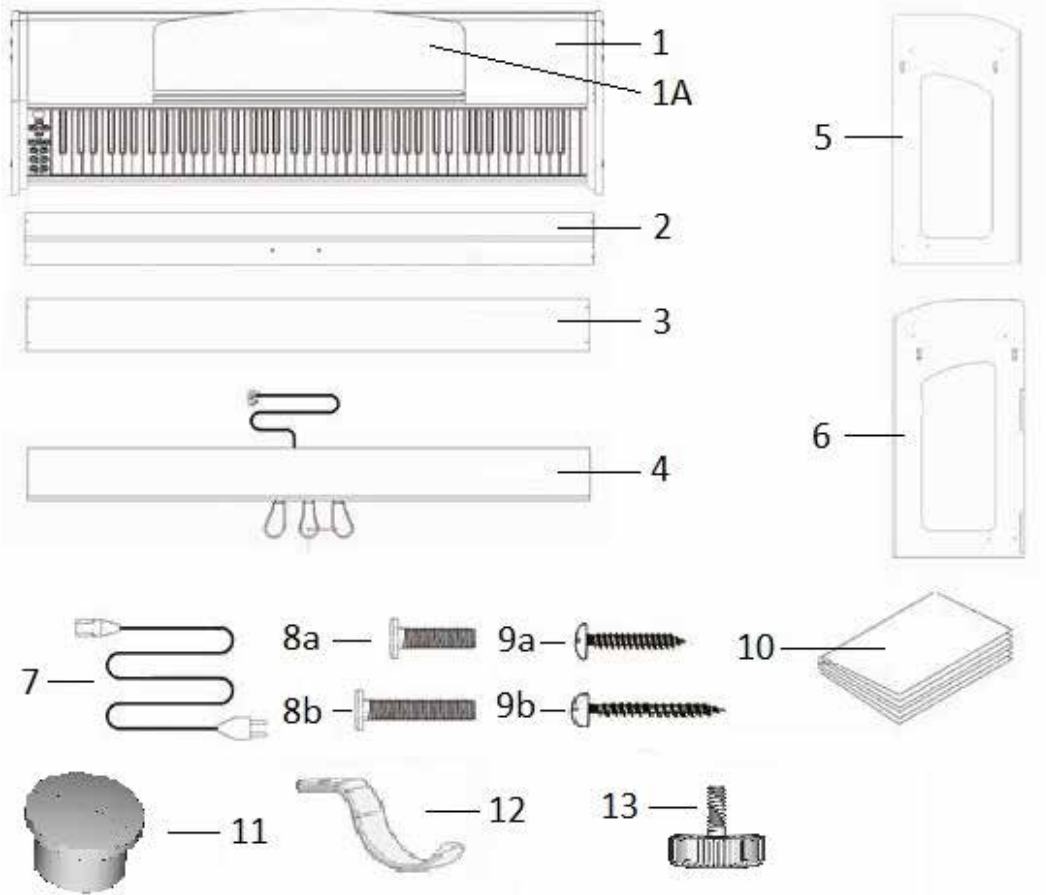

No.	Description	Quantity
1	Keyboard with keyboard cover	1
1a	Music desk	1
2	Brace pedalboard	1
3	Brace back panel, above	1
4	Pedalboard	1
5	Right side panel	1
6	Left side panel	1
7	Connecting cable power supply	1
8a	Phillips screw M6 x 16 (headphone hanger)	1
8b	Phillips screw M6 x 35	8
9a	Phillips wood screw 3.5 x 25	8
9b	Phillips wood screw 3.5 x 30	2
10	Quick Start Guide	1
11	Rubber cover	8
12	Headphone hanger	1
13	Adjustment screw	1
not shown	Cable clips	2

# 3

## ASSEMBLY INSTRUCTIONS

This section tells you how to correctly set up your digital piano. For assembly you will need:

- A size 2 phillips screwdriver
- Another person



NOTE

Do not tighten the phillips screws until all parts of your digital piano have been pre-assembled and aligned.

How to assemble your digital piano:

1. Unfold the pedal cable (not shown) and screw the adjustment screw ( 13 ) into the pedal board ( 4 ).
2. Connect the side panels (5 and 6) with the pedal board using the phillips screw (7b)
3. Now insert the pedal board brace ( 2 ). Make sure that the pedalboard is inserted into the groove provided. Then attach it to the side panels with 4 screws (9a) and 2 screws (9b) in the middle of the brace.
4. Then fix the back panel brace (3) with phillips wood screws as well (9a).
5. Then you can attach the keyboard from above. For stability, this must rest evenly on the fixed angles on the side panels. Then the keyboard (1) must be connected and fixed with the four phillips screws (8b).
6. Now screw the headphone hanger (12) on to the left underside of the keyboard by using the phillips screw ( 8a )..
7. Then align your digital piano and tighten all the screws.
8. Finally, fit the rubber covers (11) into all holes in the side panels ( 5 and 6).

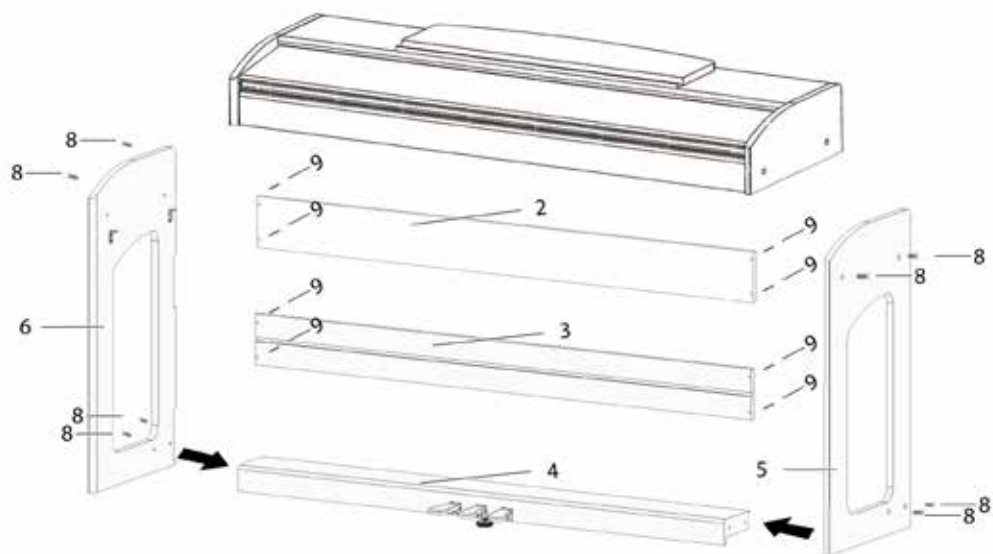

9. Place your digital piano at the desired location and make sure that the adjustment screw ( 13 ) touches the floor as shown below.



10. Insert the pedal cable true to side into the pedal cable socket on the underside of the keyboard ( 1 ). It should slide easily into the socket. Then plug the power cable ( 7 ) into the power socket on the back of the piano (not shown).

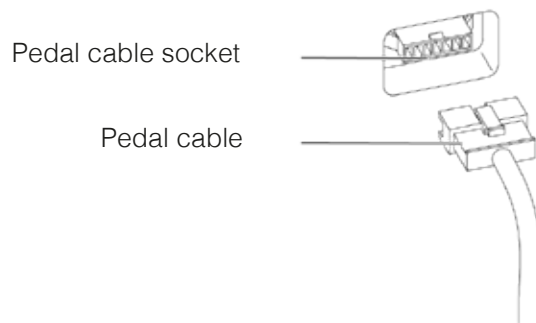

11. Set up the music desk as shown below.

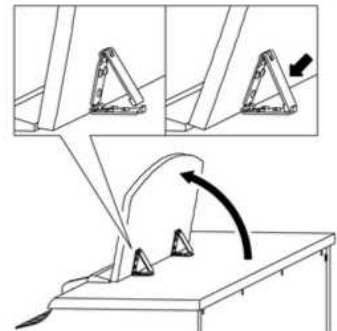

## OPENING THE KEYBOARD LID



**CAUTION**

**Please always use both hands to open the keyboard lid.**

Open the keyboard cover as shown in the diagram. Proceed in reverse order to close it.

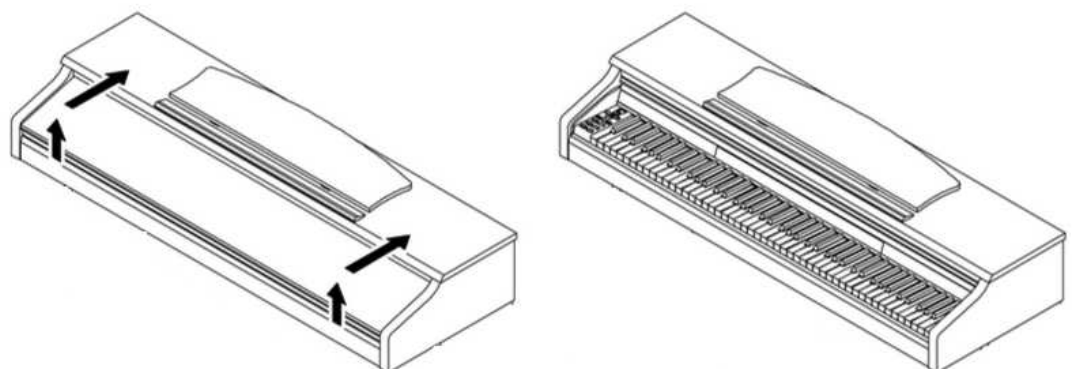

### USE WITH A KEYBOARD STAND



NOTE

It is also possible to use a keyboard stand instead of the supplied rack. In this case place the keyboard stand on level ground and position the piano centrally on top. If possible, the speakers on the bottom of the piano should not be covered or partly touched by the stand. For the connection with a standard sustain pedal you can use the 6.3mm jack socket labeled 'sustain' on the rear panel.

## 4

### FIRST STEPS

In this section, we familiarise you with the controls on your digital piano.

#### 4.1

#### THE CONTROL ELEMENTS OF YOUR DIGITAL PIANO

Your GEWA digital piano has the following controls:

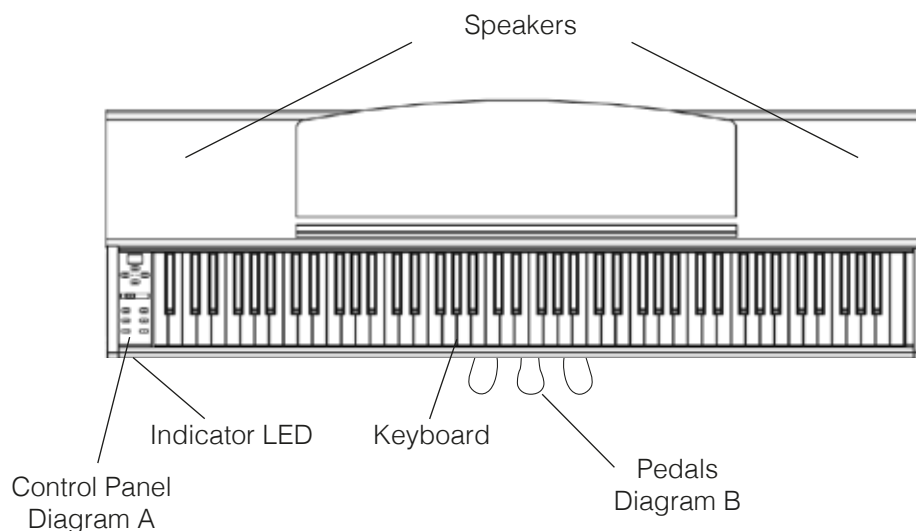

## 4.2

## CONTROL BUTTONS AND PEDALS

Diagram A

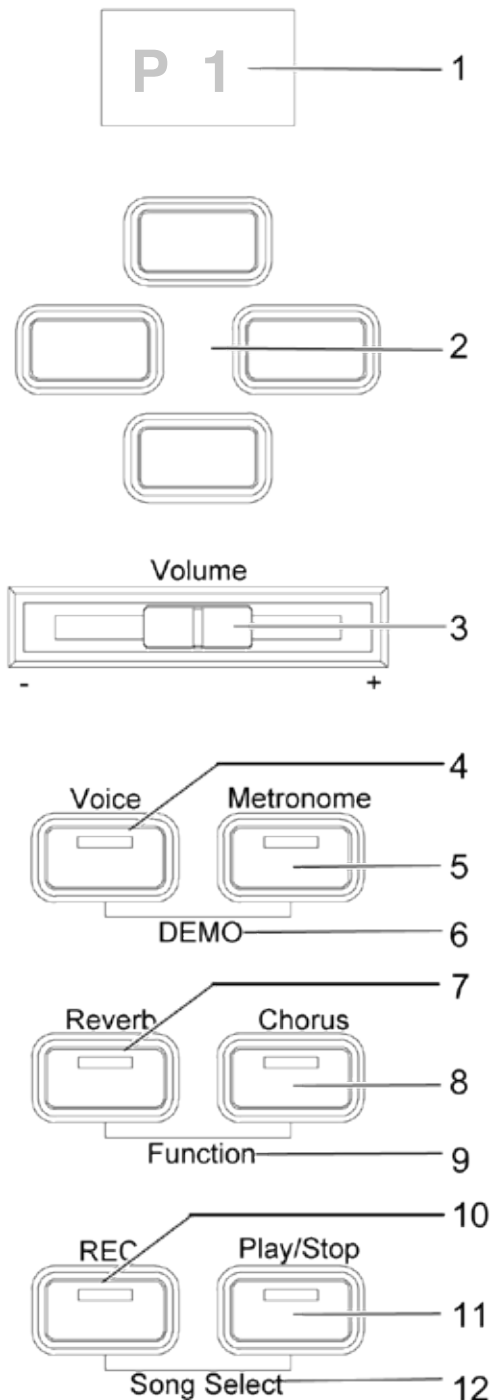
**1 Display**

Shows information about the chosen settings.

**2 Cursor keys**

Navigate through the functions here and adjust settings.

**3 Volume**

Adjusts the volume.

**4 Voice**

Choose from your digital piano's different sounds (-> page 17).

**5 Metronome**

Switch the metronome on or off here (-> page 19)

**6 DEMO**

Press the Voice and Metronome buttons at the same time to get to the DEMO function (-> page 17).

**7 Reverb**

Change the simulated room sound (-> page 18).

**8 Chorus**

Add effects to the sound (-> page 19).

**9 Function**

Activate the function menu to change various settings (-> page 20).

**10 REC**

This puts your GEWA digital piano into Recording mode (-> page 27).

**11 Play/Stop**

Start and Stop recorded music playback (-> page 27).

**12 Song Select**

Choose a memory space to record or play a song (-> page 27).

**Diagram B**

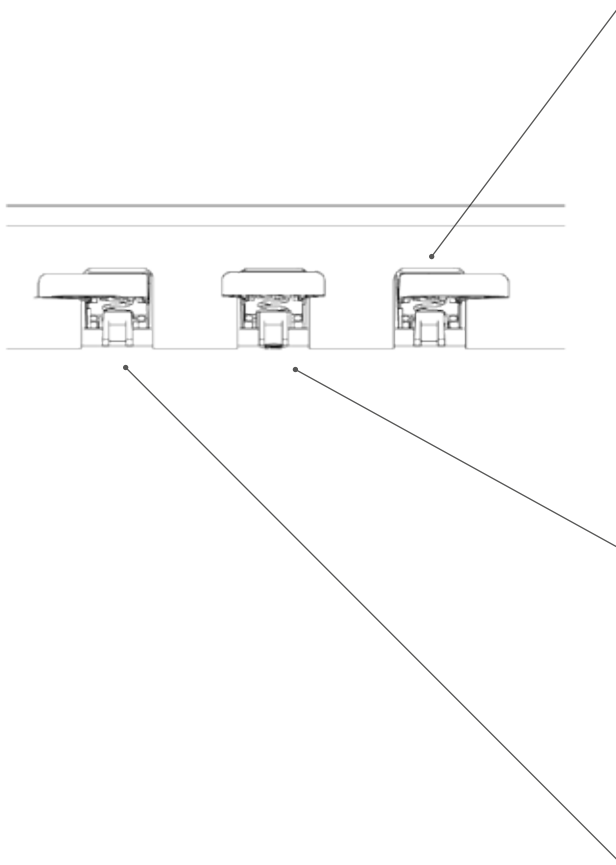

**Sustain Pedal (right side)**

The Sustain- or Damper Pedal on an acoustic grand piano lifts up all the dampers that sit on the strings. Thereby all played notes continue to sustain after the keys are released.

Furthermore, all the other strings can freely resonate, so their frequencies contribute to a richer sound.

All this is simulated by the pedal of your Gewa piano. It is also possible to play with half pedal, which means the simulated dampers are only lifted slightly, so that the sustaining notes are decaying faster than with the pedal fully depressed.

**Sostenuto Pedal (middle position)**

The Sostenuto Pedal resembles the Sustain Pedal. The only difference is that only those notes are sustaining whose keys were being depressed at the moment of actuating the pedal. All the other notes are dampened as usual.

**Piano Pedal (left side)**

When the Piano- or Una Corda Pedal is being operated, the Gewa Piano simulates shifting the keyboard action slightly to the right. The altered striking line of the imaginary piano hammers results in a differently colored tone and a slightly softer volume.

4.3

KEYBOARD / CONNECTIONS / UNDERSIDE

General View

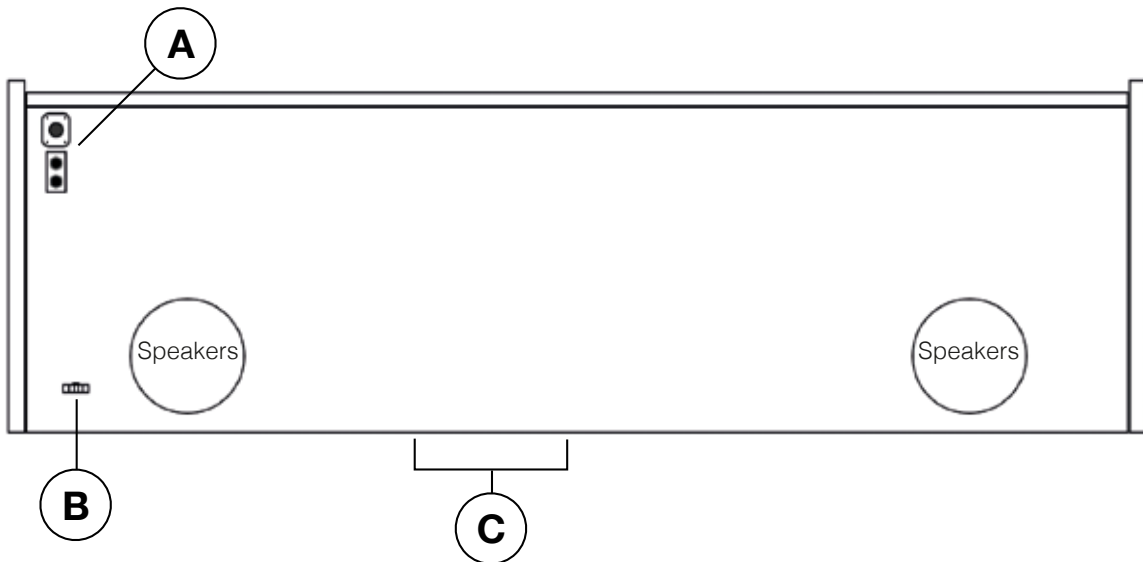
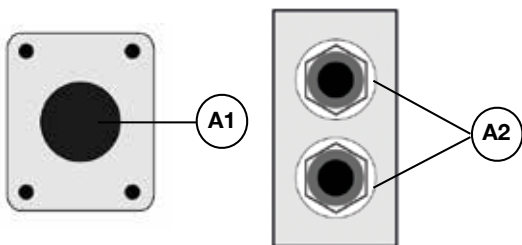

Diagram A



- A1**     **Power On/Off**
- A2**     **Headphone sockets**
- B**       **Pedal cable socket**

Diagram B



- Turn your digital piano on and off.
- Connect one or two sets of headphones here.
- Connect the pedal cable here.

## KEYBOARD / CONNECTIONS REAR PANEL

Diagram C

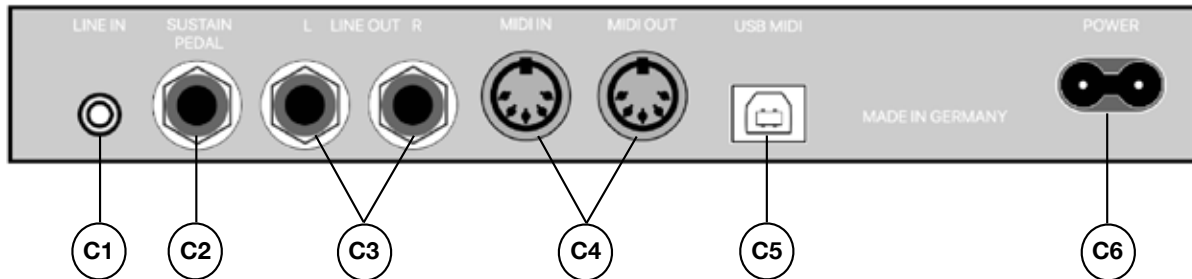

- |           |                         |  |
|-----------|-------------------------|--|
| <b>C1</b> | <b>LINE IN</b>          | This port is for external sound source playback (e.g. MP3 players) through the speaker system via a 3.5 mm jack socket. (-> page 26)   |
| <b>C2</b> | <b>SUSTAIN</b>          | You can connect a standard sustain pedal to this 6.3 mm jack socket, if you want to use your digital piano with an external stand.   |
| <b>C3</b> | <b>LINE OUT L/R</b>     | This connection is split into the stereo channels L(left) and R(right). Using 6.3 mm jack cables, you can connect these outputs to a receiver, e.g. an amplifier or a recorder (-> page 30). |
| <b>C4</b> | <b>MIDI IN/OUT</b>      | Connect MIDI devices here. (-> pages 23, 24, 30)   |
| <b>C5</b> | <b>USB-B Connection</b> | Connect your digital piano with your PC via this connection (-> page 30).  |
| <b>C6</b> | <b>Power Supply</b>     | Connect your digital piano to the power supply here, using the power cable.  |



# 5

## CONTROLS



NOTE

Any settings you change will be reset when your digital piano is turned off. Exceptions are settings on the volume control.

### 5.1

#### SWITCHING ON



TIP

Turn the volume control to its middle position before switching the digital piano on.

1. Press the On/Off button on the underside of your digital piano.
2. The Reverb and Voice LEDs light up. In addition, so will the LED indicator on the front of your digital piano.
3. Your digital piano is ready for use.

### 5.2

#### DEMO FUNCTION

The DEMO function gives you an overview of the variety of sound options that your digital piano has.

To activate the DEMO function:

1. Simultaneously press the Voice and Metronome buttons. The display shows the number of the currently selected DEMO songs.
2. Press the top and bottom cursor keys to scroll through the different demo songs.
3. Press the Play/Stop buttons to start or stop playing a song. You can accompany a DEMO song on your digital piano.
4. Press the Voice button to exit the DEMO mode.

### 5.3

#### CHOICE OF SOUNDS

Your GEWA digital piano contains more than 20 sounds:

Sounds 1 - 10		Sounds 11 - 20	
Display	Sound	Display	Sound
P1	Piano 1	Cho	Choir
P2	Piano 2	Sy1	Synth strings 1
P3	Piano 3	Sy2	Synth strings 2
P4	Piano 4	OG1	Organ 1
HAr	Harpsichord	OG2	Organ 2
EP1	E-Piano 1	OG3	Organ 3
EP2	E-Piano 2	Git	Guitar
EP3	E-Piano 3	CL	Clavinet
EP4	E-Piano 4	Vib	Vibraphone
Str	Strings	Acc	Accordion

Press the Voice button and press the left or right cursor buttons to navigate through the different sounds. The currently selected sound is shown in the display.

### 5.3.1 DUAL MODE

Your digital piano can be set to play two different sounds as you play.

To combine two sounds together:

1. Select a sound, as described above.
2. Press and hold the Voice button. The Voice button LED will start to flash. The display will show OFF.
3. Use the Left or Right cursor button to select a second sound.
4. If you play the keyboard now, both sounds will be played simultaneously.
5. You can change the volume ratio of the two sounds stored on the piano (-> Balance settings on page 22).
6. To undo the settings, press and hold the Voice button again and use the Left cursor key to reset until OFF appears in the display.



TIP

You can determine the behaviour of the Sustain Pedal in Dual Mode. (-> page 25)

### 5.4

### REVERB AND CHORUS



NOTE

Your digital piano has the ability to use the Reverb or Chorus button to mix different effects into the sounds.

- For some sounds, a reverb or chorus effect has already been added to the sound during factory production to make it more realistic. In this case, you can also disable the effects as described.
- All effect settings are retained until your digital piano is turned off. When you turn it on again, the factory settings are restored.

### 5.4.1

### REVERB

The Reverb effect simulates the ambient sound of different environments. Your digital piano has the following reverb effects:

Display	Simulation
R01	a furnished living room
R02	a slightly larger space
StG	a small stage
HA1	a larger concert hall
HA2	a cathedral

Press the Reverb button to turn the effect on or off. When the Reverb function is active, its LED lights up.

If you have activated the Reverb function, the corresponding effect will briefly be shown in the display. During this time, you can use the Left or Right cursor keys to select an effect, and use the upper and lower cursor keys to adjust the effect level.

The selected Reverb settings are adopted immediately.

## 5.4.2 CHORUS AND OTHER EFFECTS

The Chorus function includes the following effects:

Display	Name	Description
CH1	Chorus1	Makes the sound fuller and gives the same richness of sound as in an ensemble.
CH2	Chorus2	Like CH1 but more intense. Great for E-piano and string instruments.
FLG	Flanger	Similar to Chorus, with slight changes in pitch. Well suited to synthetic sounds.
PH1	Phaser1	Similar to Chorus, with periodically varying frequency changes. Well suited to synthetic sounds.
PH2	Phaser2	Like PH1 but more intense.
TR1	Tremolo1	Rhythmic influence on sound volume. Well suited to synthetic sounds.
TR2	Tremolo2	Like TR1 but more intense.
rot	Rotary	Simulates rotating speaker cabinets. Suitable for organ sounds.

Press the Chorus button to turn the effect on or off. When the Chorus effect is active, the LED on the Chorus button lights up.

If you have selected the Chorus function, the corresponding effect is briefly shown in the display. During this time, you can use the Left and Right cursor keys to select an effect, and the Upper and Lower cursor keys to adjust the effect level.

The changes in effects and effect intensity take place immediately.

## 5.5 METRONOME

Your digital piano has a built-in metronome that helps you find and maintain the right beat while you are playing.

The metronome has 7 time signatures (1/4, 2/4, 3/4, 4/4, 5/4, 3/8 and 6/8), can be adjusted in volume, and is adjustable between 32 and 250 beats per minute (Bpm).

### 5.5.1 METRONOME – SWITCHING ON/OFF

1. Press the Metronome button. The Metronome button's LED lights up and the metronome is activated.
2. The next time you press the Metronome button, the LED goes out and the metronome is deactivated.

### 5.5.2 METRONOME – CHANGING SPEED

1. Switch the metronome on.
2. Use the upper and lower cursor keys to increase/decrease the tempo in increments of 10, and press the left and right cursor keys to increase/decrease the tempo in increments of one. The current tempo is shown in the display.

### 5.5.3 CHANGING TIME SIGNATURE

1. Press and hold the Metronome button. The currently set time signature appears in the display.
2. Press the right or left cursor keys to find the desired time signature.
3. Release the Metronome button. The selected time signature is set and played back.

### 5.5.4 METRONOME – VOLUME ADJUSTMENT

1. Press and hold the Metronome button. The set time signature is shown in the display.
2. Press the upper or lower cursor keys to adjust the volume of the metronome.
3. Release the Metronome button. The set metronome volume will be played back.

## 6



NOTE

## FUNCTIONS MENU

**Any settings you change will be reset when your digital piano is turned off.**

You can change a variety of settings in the Functions Menu. To enter the Functions Menu, press the Reverb and Chorus buttons simultaneously.

Navigating the Functions Menu:

1. Simultaneously press the Reverb and Chorus buttons. The display alternately flashes the abbreviation for the setting to be made and the set value.
2. Press the left or right cursor keys to change from setting to setting.
3. Press the upper or lower cursor keys to change the values of the settings. Changes to the values are applied immediately.
4. Press the Reverb button to exit the menu.

## 6.1 TABLE OF SETTINGS

<b>Display</b>	<b>Description</b>	<b>Adjustable values</b>
trA	Transpose (-> page 21)	-6 to 6
tun	Fine-tuning the sounds (-> page 22)	270 to 530 (in increments of 5)
tch	Sets keyboard sensitivity	OFF / HE2 / HE1 / Std / Li1 / Li2
bAl	Change the volume of two sounds in dual mode (-> page 22)	1-5 to 5-1
bri	Brilliance settings (-> page 23)	-6 to 6
Lcl	Local Control functions (-> page 23)	ON / OFF
tr.C	Set MIDI transmission channel (-> page 23)	1-16
PG.C	Change Program function (-> page 24)	ON / OFF
PM.d	Piano-Mode (-> page 24)	ON / OFF
L.Pd	Pedal behaviour in Dual Mode (-> page 26)	ON / OFF
tMP	Change the tuning of your digital piano (-> page 25)	Equ / MAJ / Min / Pyt / MEA / MS3 / BG3
rt.n	Change the fundamental tuning (-> page 25)	C / C' / d / d' / E / F / F' / G / G' / A / A' / b
SY.n	Adjust string resonance (-> page 25)	0-20
dMP	Adjust damper-resonance for the piano sound (-> page 26)	0-20
L.In	Line In / Volume (-> page 26)	0-20
S.En	Auto Power Off (-> page 26)	Off, 15, 30, 60, 90, 120 minutes

## 6.2 TRANSPOSE / TRANSPOSITION

If you want to play a piece in a different key (for example, to adjust to the pitch of a singer or another instrument), you can use the transposition tool to increase or decrease the pitch of your digital piano in 6 semitone steps.

To transpose the sound of your digital piano:

1. Activate the Functions menu (-> page 20). The abbreviation "trA" and the currently set value flash alternately in the display.
2. Press the upper or lower cursor keys to change the pitch. You can test it out on the keyboard as you change the pitch.
3. When you have found the correct pitch, press the Reverb button to exit the Functions menu.

**6.3 FINE-TUNING THE SOUNDS**

If you need to fine-tune the sounds of your digital piano, you can do it in this way:

1. Activate the Functions Menu (-> vpage 20).
2. Press the left or right cursor keys until "tun" and the current setting in the display.
3. Press the upper or lower cursor keys to change the tuning of your digital piano. The higher you set the values in the display, the higher you tune your digital piano.
4. Press the Reverb button to exit the Functions Menu.

**6.4 TOUCH-FUNCTION / TOUCH SENSITIVITY**

You can change the touch sensitivity of the keyboard with the Touch Function.

The more sensitive the keyboard is set, the less force you need to press the keys to produce a louder sound.

To change the touch sensitivity of your digital piano:

1. Activate the Functions Menu (-> page 20).
2. Press the right or left cursor keys until the display alternately flashes "tch" and the set value.
3. Press the upper or lower cursor keys to set the desired touch sensitivity.
4. Once you have found the right touch sensitivity, press the Reverb button to exit the Functions Menu.

The following levels of touch sensitivity are adjustable:

- > OFF – Same volume, regardless of the velocity
- > HE2 – Very heavy touch sensitivity
- > HE1 – Heavy touch sensitivity
- > Std – Default setting, normal touch sensitivity
- > Li1 – Light touch sensitivity. Suitable for inexperienced players.
- > Li2 – Very light touch sensitivity. Suitable for inexperienced players or children.

**6.5 BALANCE SETTINGS**

The Balance Settings allow you to change the volume balance between two combined sounds (-> page 18).

Proceed as follows:

1. Activate the Functions Menu (-> page 20).
2. Press the left or right cursor keys until "bAl" and the set value alternately appear in the display.
3. Use the upper or lower cursor keys to set the desired volume ratio.
4. Press the Reverb button to exit the Functions Menu.

## 6.6 BRILLIANCE SETTINGS

If you want an even brighter tone, you can achieve this via the Brilliance Settings.

Proceed as follows:

1. Activate the Functions Menu (-> page 20).
2. Press the left or right cursor keys until "bri" and its current setting appear in the display.
3. Use the upper or lower cursor keys to set the desired brilliance.
4. Press the Reverb button to exit the Functions Menu.

## 6.7 MIDI TRANSMISSION CHANNEL

Use the MIDI transmission channel to specify which channel (1-16) should transmit signals between the digital piano and the connected device.

To select a MIDI transmission channel, proceed as follows:

1. Activate the Functions Menu (-> page 20).
2. Press the left or right cursor keys until "tr.C" and its current set value alternately appear in the display.
3. Use the upper or lower cursor keys to set the desired channel.
4. Press the Reverb button to exit the Functions Menu.



NOTE

In case a sound combination is selected, (-> page 18), you always choose the transmission channel of the first sound. The additional sound is automatically transmitted via the next highest MIDI channel.

Example:

After selecting two sounds in Dual Mode, you set channel 4 as the MIDI transmission channel. The first selected sound is then transmitted via channel 4, while the second sound is transmitted via channel 5.

## 6.8 LOCAL CONTROL

The Local Control function allows you to use the keyboard of your digital piano in MIDI OUT mode without playing the internally associated sound.

The MIDI OUT connector continues to output keyboard data. This is useful if you want to operate a different instrument or a computer-based recording program using the keyboard of your digital piano, without producing sound from the digital piano at the same time.

If you are in situation as described, set Local Control to OFF (Keyboard only transmits notes via Midi, no sound being produced in the piano itself). To return to normal behavior, set Local Control to ON.

To adjust the Local Control, proceed as follows:

1. Activate the Functions Menu (-> page 20).
2. Press the left or right cursor keys until "Lcl" and its current set value alternately appear in the display.
3. Use the upper or lower cursor keys to set the Local Control to ON or OFF.
4. Press the Reverb button to exit the Functions Menu.

## 6.9 PROGRAM CHANGE FUNCTION

The Program Change function indicates whether the program change information is transmitted to a MIDI device connected to the MIDI OUT terminal.

To adjust the Program Change Function, proceed as follows:

1. Activate the Functions Menu (→ page 20).
2. Press the left or right cursor keys until "PG.C" and its current set value alternately appear in the display.
3. Use the upper or lower cursor keys to activate or deactivate the function.
4. Press the Reverb button to exit the Functions Menu.

## 6.10 PIANO MODE

In Piano Mode, you decide how the keyboard data of channels 1 and 2 of the MIDI IN connector are played back. When the Piano Mode is turned ON, channels 1 and 2 will play with piano effects when a piano sound is selected. The Chorus effect is not available for channels 1 and 2 when Piano Mode is activated. There is no piano effect for channels 3-16, but the GM chorus is available.

If the Piano Mode is disabled, the piano effect will not be available for any of the 16 MIDI channels, but the GM chorus effect will be available for all channels.



NOTE

**By default, the Piano Mode is turned on and automatically controlled by the signaling device.**

To adjust the Piano Mode, proceed as follows:

1. Activate the Functions Menu (→ page 20).
2. Press the left or right cursor keys until "P.Md" and its current set value alternately appear in the display.
3. Use the upper or lower cursor keys to activate or deactivate the Piano Mode.
4. Press the Reverb button to exit the Functions Menu.



## 6.11 CHANGING THE TUNING / TEMPERAMENT

You can adjust the tuning, also called 'temperament', of your digital piano e.g. to play music from older epochs with the utmost authenticity. Due to a variety of works from various pre-Bach epochs, this is especially useful for the harpsichord sound of your GEWA digital piano.

Proceed as follows:

1. Activate the Functions Menu (-> page 20).
2. Press the left or right cursor keys until the display alternately shows "tMP" and the current setting.
3. Use the upper or lower cursor keys to set the desired tuning/temperature:
  - EQU=Equal Temperament (Standard tuning for modern pianos)
  - MAJ=Pure major (Pure tuning for modal music like Indian classical music)
  - MIN=Pure minor (Pure tuning for modal music in minor)
  - PYT=Pythagorean (Tuning system based on pure 5ths, suitable for medieval music)
  - MEA=Meantone (Based on pure 3rds, suitable for Renaissance and Baroque music)
  - MS3=Werkmeister III (Well tempered Tuning system which inspired J. S. Bach's Well Tempered Clavier)
  - BG3=Kirnberger III (A different well tempered system widely used in Baroque organs)
4. Press the Reverb button to exit the Functions Menu.

### 6.11.1 CHANGING THE ROOT NOTE

You can select the root note for the selected temperament. Proceed as follows:

1. Activate the Functions Menu (-> page 20).
2. Press the left or right cursor keys until "rt.n" and the set value appear in the display.
3. Use the upper or lower cursor keys to set the desired root note.
4. Press the Reverb button to exit the Functions Menu.

## 6.12 ADJUSTING STRING RESONANCE

Your digital piano simulates the behaviour of piano strings, which indirectly resonate as a result of the keys striking on an acoustic piano.

You can set this level of resonance as follows:

1. Activate the Functions Menu (-> page 20).
2. Press the left or right cursor keys until "SY.n" and the set value appear in the display.
3. Use the upper or lower cursor keys to set the desired string resonance.
4. Press the Reverb button to exit the Functions Menu.

**6.13**                    **ADJUSTING DAMPER RESONANCE**

You set the string resonance (-> page 25) here when you press the damper pedal. Proceed as follows:

1. Activate the Functions Menu (-> page 20).
2. Press the left or right cursor button until "dMP" and the set value alternately flash appears in the display.
3. Use the upper or lower cursor keys to set the desired damper resonance.
4. Press the Reverb button to exit the Functions Menu.

**6.14**                    **SET LINE-IN VOLUME**

Here you can define the volume of the audio device connected via the LINE IN/AUX port in relation to the overall volume of the piano.

To alter the LINE IN volume, proceed as follows:

1. Activate the Functions Menu (-> page 20).
2. Press the left or right cursor button until "L.In" and the set value alternately appear in the display.
3. Use the upper or lower cursor keys to set the desired volume.
4. Press the Reverb button to exit the Functions Menu.

**6.15**                    **AUTO POWER OFF**

In order to save energy, your digital piano possesses an Auto Power Off. After the selected amount of time in which you do not play a key or press a button, the piano turns off automatically.

To adjust the Auto Power Off, proceed as follows:

1. Activate the Functions Menu (-> page 20).
2. Press the left or right cursor keys until "S.En" and its current set value alternately appear in the display.
3. Use the upper or lower cursor keys to set the desired period of time.
4. Press the Reverb button to exit the Functions Menu.

**6.16**                    **LAYER PEDAL**

When layering two sounds (-> page 18), you can influence the behaviour of the Sustain Pedal. If OFF is selected, both sounds will be sustained while the right pedal is pressed down. If ON is selected, the second chosen sound will not be sustained.

To adjust the pedal behaviour, proceed as follows:

1. Activate the Functions Menu (-> page 20).
2. Press the left or right cursor keys until "L.Pd" and its current set value alternately appear in the display.
3. Use the upper or lower cursor keys to activate or deactivate the Layer Pedal.
4. Press the Reverb button to exit the Functions Menu.

## 7

## RECORDING AND PLAYBACK FUNCTIONS

Your digital piano has a feature to record your playing. You can save up to three pieces on the digital piano.

## 7.1

## RECORDING MUSIC

To activate the recording mode, follow these steps:



NOTE

**Your recording will be automatically saved to the first of three possible memory slots. If you want to use this one, you can leave out step 1 and 2.**

1. Press the REC and Play / Stop buttons simultaneously to activate the Song-Select Menu.
2. Use the upper and lower cursor keys on the display to select the recording memory space (SN.1-SN.3) on which you want to record.
3. Press the REC button. The corresponding LED now lights up while the Play / Stop Button LED starts flashing.
4. Just start playing. The recording begins when you press the first key or the pedal. In the meantime, three points appear alternately in the display.
5. Press the Play / Stop button to stop recording. The recording will be saved automatically.



NOTE

**Recorded songs will not be deleted after your digital piano is turned off.**



NOTE

If the memory space you want to record on is already occupied, you might have to delete the previous recording first. Proceed as described on page 25 under “Delete Recordings”.

## 7.2

## PLAYBACK OF RECORDINGS



TIP

After recording, you can play back the recorded song immediately by simply pressing the Play / Stop button.



TIP

While a recording is playing, you can continue to play the digital piano and accompany the recording with your playing.

1. Select a recording memory slot, as described at 7.1.
2. Press the Play / Stop button to start playback.
3. Press the Play / Stop button if you want to stop the playback prematurely. Otherwise the entire recording will be played back.

## 7.3

## DELETING RECORDINGS

To delete a recording, follow these steps:

1. Select a used recording memory space (-> page 25).
2. Press and hold the REC button. “del” and “YES” will alternately appear in the display.
3. Press the right cursor key to delete the recording, or cancel the action with the REC button.

# 8

## USER CALIBRATION OF THE KEYBOARD

Each GEWA digital piano is calibrated during the manufacturing process. That means that the velocity behaviour (dynamics) of each keyboard is measured in a special procedure; it is then tuned precisely in order to achieve uniformity between the volume of the individual tones, and this individual tuning is stored on each device.

As with an acoustic piano or grand piano, it can also happen with a digital piano that the complex mechanism deviates slightly from its original adjustment during transportation or heavy use over a long period of time, causing slight irregularities to occur.

With an acoustic upright or grand piano, a piano-tuner or technician would regularly balance the mechanics to restore its uniform playability.

Your GEWA digital piano is much less sensitive to transport or stress. However, if it happens that one or more keys play too loudly or too quietly, you can easily adjust this in the software of the piano itself.

To do so, we offer the calibration mode for all our models. Although the process is very easy, we recommend only experienced users carry out a calibration themselves, and in case of doubt, to consult a piano technician or Gewa dealer.

### 8.1 SELECTING THE USER CALIBRATION MODE

While holding down the Reverb button, press the Chorus button twice in rapid succession.

Now the three LEDs of the Reverb, Chorus and Metronome buttons will flash and the display will alternately show the selected key and its calibration value.

### 8.2 CREATING A USER CALIBRATION

If you have never used the calibration mode, the piano will normally start up with the factory calibration. If you change the calibration of your digital piano, these changes will be written to the User Calibration memory and the piano will start up with this calibration. You can change the user calibration at any time or return to the factory settings calibration.

To calibrate, perform the following steps:

1. Select the key you want to calibrate simply by playing it on the keyboard. The piano automatically recognizes the key and it appears in the display. Alternatively, you can use the left and right cursor keys to move from one key to the next.
2. Now use the upper and lower cursor keys to set the calibration value.
3. Repeat the process for each key you want to calibrate.



NOTE

The sharp sign (“#”) is shown on the display as „ ’ “, so, for example, “C#4” will be displayed as “C’4”.



TIP

For comparison, keep playing the adjacent keys with the same intensity to hear whether the tone being calibrated fits evenly. Before calibrating up and down, make sure that the desired key is shown in the display.

### 8.3 COMPARE FACTORY AND USER CALIBRATION

To check that the user calibration was successful, it is recommended that you compare the touch sensitivity to the original factory calibration.

- To play the factory calibration, press the Voice button.
- To play the created user calibration, press the Metronome button.

The respective LED flashes to indicate which calibration is currently loaded. The user calibration can be adjusted at any time, while the factory calibration is invariable.

### 8.4 EXIT CALIBRATION MODE

There are several options when exiting the calibration mode:

- To discard all changes, simply press the Reverb or Chorus button.
- To save the user calibration, press the REC button. The display now alternately shows "Sto" and "Yes". Press the right cursor key to confirm or the left cursor key to cancel and return to the calibration mode.
- To clear the user calibration and restore the factory calibration settings, press and hold the REC button while pressing the Play button. The display now alternately shows "Res" and "Yes". Press the right cursor key to confirm or the left cursor key to cancel and return to the calibration mode.



NOTE

If you restore the factory calibration when exiting calibration mode, you will need to restart the piano to load the calibration.

# 9

## CONNECTING EXTERNAL DEVICES

Find out more about the connectivity options for your digital piano here.

### 9.1 CONNECTING HEADPHONES

Connect your headphones by using one of the two 6.3 mm jack sockets below the keyboard.



NOTE

When headphones are connected to one or both sockets, the speakers of your digital piano are automatically muted until you remove BOTH headphones.

### 9.2 CONNECTING A PLAYBACK DEVICE

You can connect playback devices, such as a CD or MP3 player, to the digital piano. This can be useful if you want to rehearse a song and listen to it while playing. The song is audible from the player through the digital piano speakers and the headphones connected to the digital piano. Use the volume control to alter the overall volume. If you exclusively want to set the LINE IN volume, go to paragraph 6.14 (-> page 25)

### 9.3 CONNECTING AN AMPLIFIER

If the sound of your digital piano is too quiet through the built-in speakers, you can connect it to a suitable amplifier via the LINE OUT outputs on the back of the keyboard.

### 9.4 CONNECTING TO PC

You can also connect your digital piano to your PC via the USB B port on the back.

To connect your PC to your digital piano:

1. Turn off your digital piano and PC.
2. Connect your digital piano to the PC with a suitable USB cable.
3. Switch on your digital piano and the PC.

As a rule, your digital piano is automatically recognized by your PC and you can exchange data with appropriate software. This is very useful if you want to use a recording program on your PC to record and edit your playing, for example.



NOTE

In order to monitor the data transfer between the digital piano and the PC, you will typically find an area on the user interface of your PC software, which shows you the MIDI note and controller data.

You will find all information on updates at our website:  
[www.gewakeys.com](http://www.gewakeys.com)

# 10

## USEFUL INFORMATION

At this point, we would like to provide definitions for a few terms that are used in this manual.

We also explain the special features of your digital piano here.

### 10.1

#### INDEX

Term	Definition
MIDI	<p>Musical Instrument Digital Interface is a data transmission protocol. That means that musical control information is transmitted between electronic instruments such as digital pianos, keyboards, synthesizers, drum computers and also PCs and laptops. To exchange this control information, the instruments/computer need MIDI connectors and a connection must be made between them. There are different MIDI connections with different functions: MIDI-IN, MIDI-OUT and MIDI-THRU. The latter forwards the data received via the MIDI input unaffected to another MIDI device.</p> <p><b>Example:</b> When you press a key on the digital piano, small data packages are sent via its MIDI OUT port. These data packages contain information concerning the pitch and velocity of the corresponding tone. They can, for example, be recorded, stored and played back on the computer. Moreover, they can be transformed into musical notation on screen if there is an appropriate program.</p>
GM	<p>General-MIDI (abbrev. GM) standardises significantly more than the universal MIDI standard. The latter is both a hardware and protocol specification. General-MIDI also specifies content. GM sets a minimum standard for the allocation of instruments on the 128 program slots. According to GM, a compatible tone generator must be able to produce 24 sounds at a time. According to GM, further control parameters are defined e.g. the effect control.</p>
General MIDI Sounds	<p>Sounds or instruments according to the specifications of the general MIDI standard.</p>
Reverb	<p>The device simulates how the sound in a room would be. This sound simulation is already preconfigured for some sounds to make them more realistic.</p>
Chorus	<p>The Chorus Effect adds a copy of the played notes which is slightly detuned. Therefore the sound seems fuller.</p>
Samples	<p>Samples are sound recordings of instruments. The notes of the instruments are recorded and stored individually. When you play a note on the keyboard of the digital piano, the corresponding recordings are played back.</p>
Polyphony	<p>With electronic instruments, the term 'polyphony' refers to how many tones can be played at the same time.</p>

## 10.2

### WARRANTY

The dealer from whom the device was purchased warrants the material and manufacture of the device for a period of 2 years from the date of purchase. In the case of a defect product, the buyer is initially only entitled to a subsequent performance. This includes either the repair or the delivery of a replacement product. Replaced equipment or parts become the property of the dealer.

If the subsequent performance fails, the buyer can either demand a reduction in the purchase price or withdraw from the contract and, if the defect is to be represented by the dealer, claim for damages or reimbursement of wasted expenditure.

The buyer must notify defects to the dealer without delay. Proof of warranty is to be provided by a proper confirmation of purchase (proof of purchase e.g. invoice)

Damage caused by force or other external influences are not covered by the warranty, nor are the consumption of consumer goods such as rechargeable batteries, strings, skins or seals. If you suspect a warranty claim with your device, contact your dealer during normal business hours.



## 11

## TROUBLESHOOTING AND REPAIR

If malfunctions occur, you can use the tips listed here to find and solve the issue yourself. If you are unsuccessful, please contact your dealer.

<b>Possible cause and solution</b>		
<b>Problem</b>	<b>Possible cause(s)</b>	<b>Possible solution(s)</b>
The piano does not switch on	<ul style="list-style-type: none"> <li>• Power plug is not plugged in.</li> <li>• Power cable is not connected properly.</li> </ul>	<ul style="list-style-type: none"> <li>• Check the power cable and its connections.</li> <li>• Reconnect it if necessary.</li> </ul>
Crackling/pop noise when switching on/off.	<ul style="list-style-type: none"> <li>• This is normal and may occur when the digital piano is turned on and off.</li> </ul>	
Noise occurs through speakers during operation.	<ul style="list-style-type: none"> <li>• Interference with other devices (e.g. mobile phones).</li> </ul>	<ul style="list-style-type: none"> <li>• Increase the distance between the digital piano and other devices or turn off the other devices.</li> </ul>
The sound is too low or is not audible at all.	<ul style="list-style-type: none"> <li>• The volume control is set too quietly.</li> <li>• Headphones are connected.</li> </ul>	<ul style="list-style-type: none"> <li>• Make the volume control go louder.</li> <li>• Remove them.</li> </ul>
The pedals are not working properly.	<ul style="list-style-type: none"> <li>• The pedal cable is not properly connected.</li> </ul>	<ul style="list-style-type: none"> <li>• Check that the pedal cable is properly in the socket.</li> <li>• Reconnect if necessary.</li> </ul>

# 12

## TECHNICAL SPECIFICATIONS

<b>Name</b>	<b>Features</b>
Dimensions W x D x H (with music desk)	137.6 x 42.9 x 80.6 (96.6) cm
Weight	42.3 kg
Power consumption during operation	max 75 Watt
Keyboard	88 keys, Concert Pianist, Grand Touch
Touch sensitivity	6 levels (2 x light, medium, 2 x hard and constant)
Pedals	Damper-, Sostenuto- and Piano Pedal
Sound source	GEWA 4-layer music samples
Polyphony	max 256 notes
No. of integrated sample-sounds	20
Amplified rated power RMS	2 x 20 Watt
Speakers	2 Full range, stereo speakers
Recording	Integrated recorder
Recording format	Standard MIDI-file (Format 0, SMF)
Connections	<ul style="list-style-type: none"> <li>- Power supply</li> <li>- MIDI IN</li> <li>- MIDI OUT</li> <li>- Aux In</li> <li>- Aux Out</li> <li>- 2 x headphone jacks (6.3 mm jack)</li> <li>- USB Type B</li> <li>- Sustain Pedal Input</li> </ul>



Manufacturer:  
GEWA music GmbH  
Werkstraße 1  
08626 Adorf  
GERMANY  
[www.gewamusic.com](http://www.gewamusic.com)  
Version 1.0



Errors and omissions excepted!